



Gobierno de Reconciliación
y Unidad Nacional
El Pueblo, Presidentes!

MINED
Un Ministerio en la Comunidad

MINISTERIO DE EDUCACIÓN

ACTIVITY BOOK 1



**FIRST
GRADE**

**DIRECCIÓN DE EDUCACIÓN
PRIMARIA MULTIGRADO Y A DISTANCIA**

AUTORIDADES:

Mendy Arauz Silva Ministra de Educación

Salvador Vanegas Guido Asesor de la Presidencia Para Asuntos Educativos

Cristian Danilo Cerda Cerda Director General de Primaria

RECOPIACIÓN:

Anielka Ortiz Orozco Asesor Pedagógico

Revisión Técnica Asesores Pedagógicos:

Lidamar Tamara Sanchez Acevedo

Jamyn Efrain Garcia

Melkis Manuel Barrios

Karla Ivanessa Soza Medina

Diseño, diagramación, portada y contraportada

Martha García Pérez

Fuente de Financiamiento: Recursos del Tesoro

PRESENTACIÓN

El Ministerio de Educación, de conformidad con la Estrategia Nacional de Educación “Bendiciones y Victorias 2024-2026” en todas sus modalidades, concretamente con el Eje 1 Educación para la Vida, el Lineamiento 8 Fortaleceremos el Aprendizaje del Inglés como Segundo Idioma para Estudiantes y Docentes, en todos los niveles educativos, como herramienta para el desarrollo profesional y personal, y en coherencia con el Plan de Educación 2022-2026, Objetivo 1, Tema Estratégico 2, Línea de Acción 2.1: Consolidación del Aprendizaje del Inglés como Segundo Idioma en estudiantes de Educación Primaria, en los que se establece la incorporación del inglés como segundo idioma en planes de estudio de todas las modalidades educativas, para el desarrollo y certificación de habilidades lingüísticas con estándares internacionales de acuerdo a las normas del Marco Común Europeo de Referencias para las Lenguas, presenta el Cuaderno de Trabajo Activity Book 1st Grade, a fin de reforzar el aprendizaje del idioma inglés en Educación Primaria.

Este recurso didáctico incluye diversas actividades formativas, dirigidas a niñas y niños de primer grado en los centros educativos públicos de Primaria Multigrado, para desarrollar procesos de aprendizaje adecuados y la apropiación del idioma inglés.

Estas actividades han sido concebidas y diseñadas para fomentar las habilidades lingüísticas de este idioma de manera didáctica, contando con el compromiso de la maestra y el maestro, el protagonismo de los estudiantes y el invaluable apoyo de madres y padres de familia.

Activity 1: Listen, say and color. My Beautiful School!

Hi / Goodbye
Teacher's name/ peers' names
what's your name? / My name's



Activity 2: Color the hands
○ Left hand - Goodbye: red ○ Right hand- Hello: green

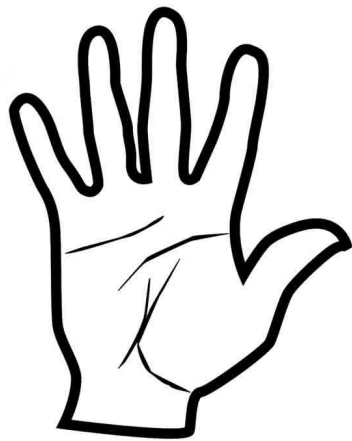

Goodbye

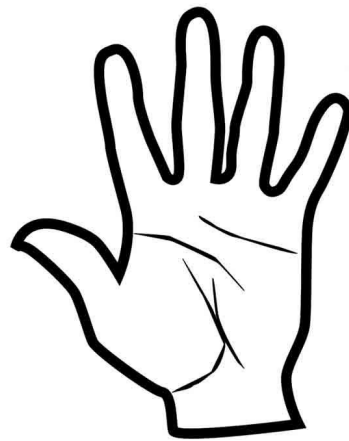

Hello

Activity 3: Draw yourself and complete.

What's your name?

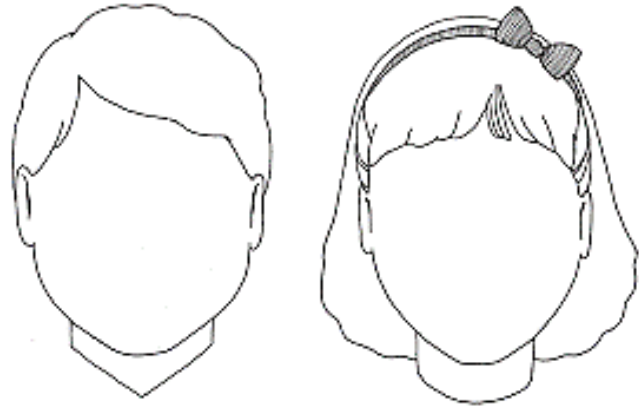

My name is _____

Activity 4: Ask, answer and check (✓).

What's your name?
My name's ...



Activity 5: Look, listen and Circle.



listen



draw



sing

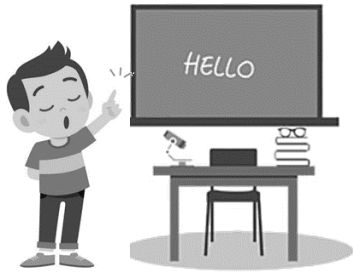

Point



say

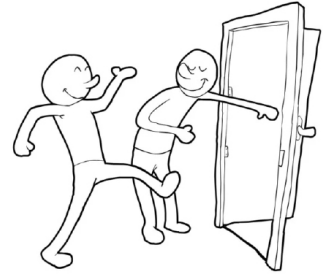

open

Activity 6: Trace and color.



Book



Pencil

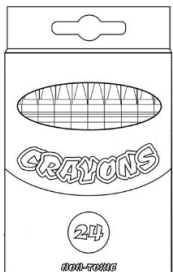

Notebook

Crayons

Board

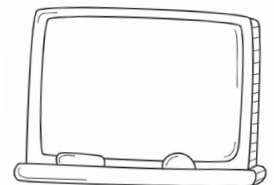

Activity 7: Ask and answer.

What's this?
It's ...

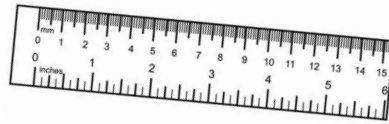
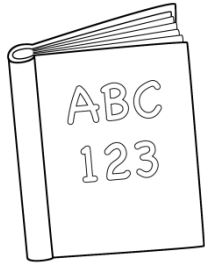

Activity 8: Look and match (—).

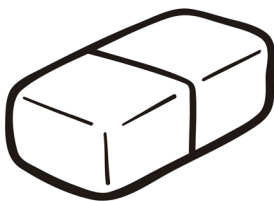
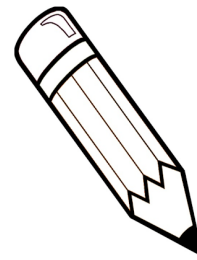
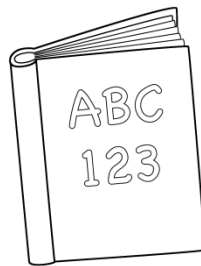

Pencil

Ruler

Eraser

Book

School bag

Pencil case

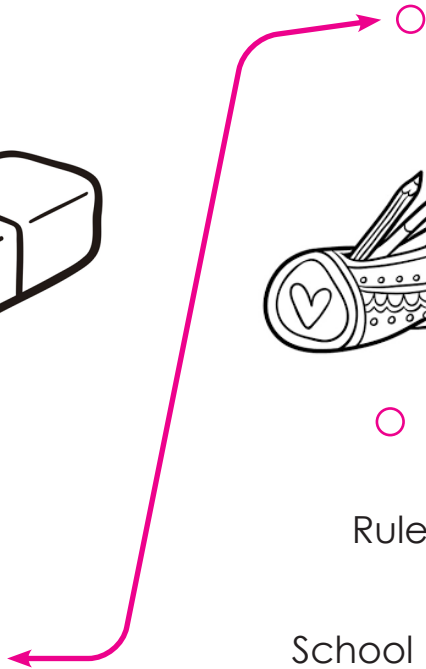

Activity 9: Listen, say and check (✓).

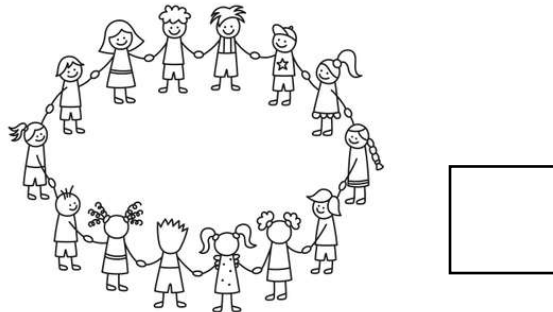
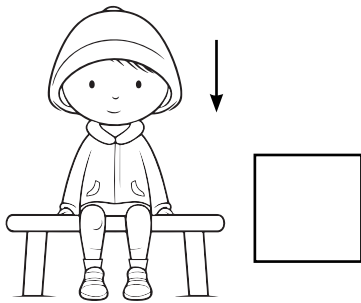
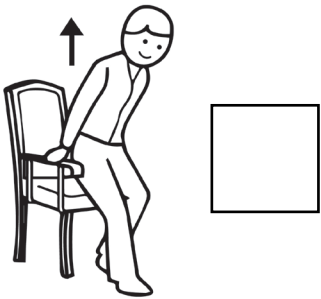

Activity 10:

Look and match (—).

Stand up

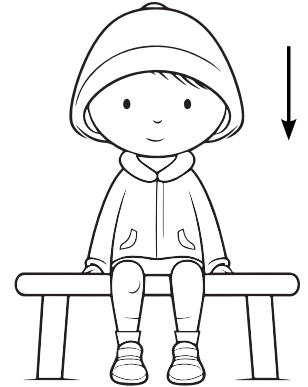

Clap your hand



Sit down



Make a circle



Activity 11:

Look, trace and say.



Stand up

Sit down

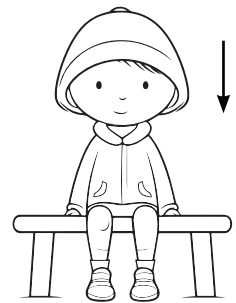

Claps

Make a circle



Activity 12: Look, listen and color.

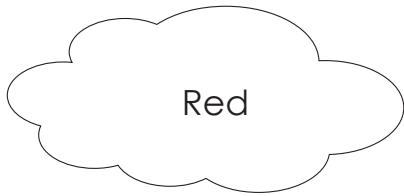

Red

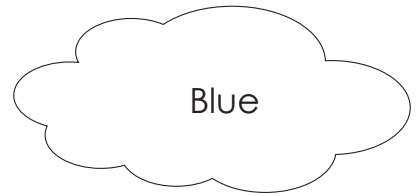

Blue

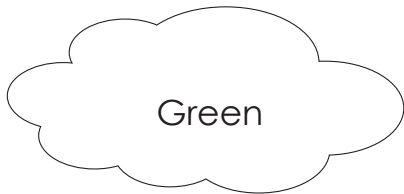

Green

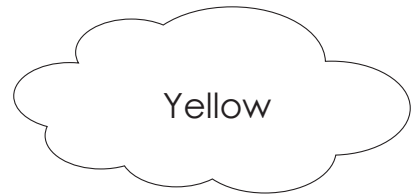

Yellow

Activity 13: Color and trace.

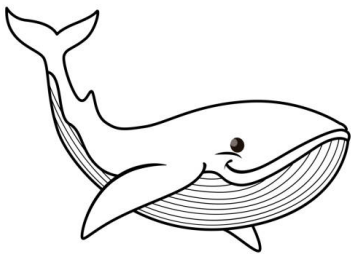

Blue

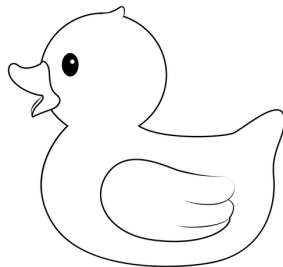

Yellow

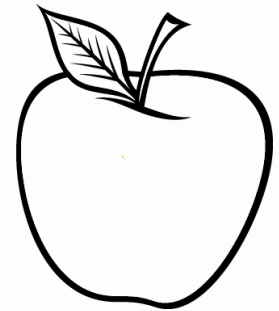

Red

Activity 14: Listen, say and draw.

1. This is my teacher.

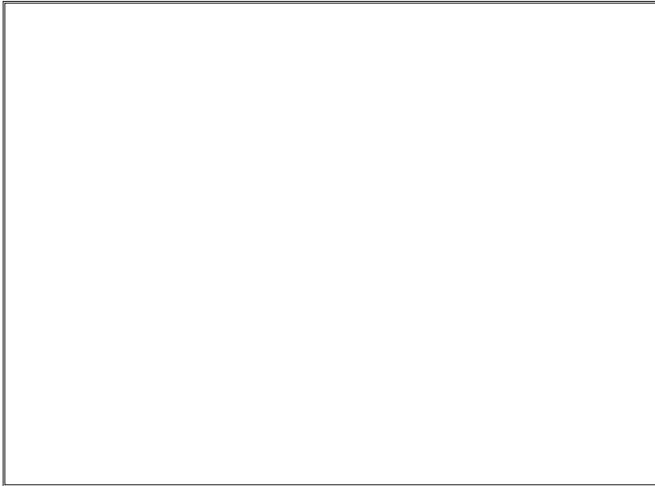

3. This is my friend.

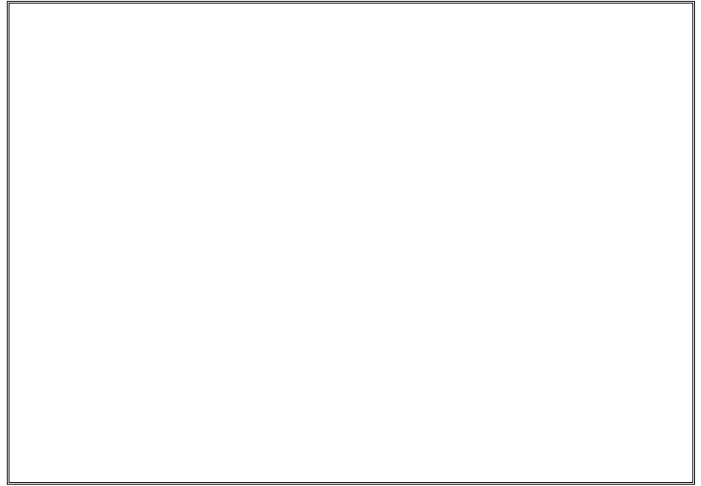

2. This is my school.

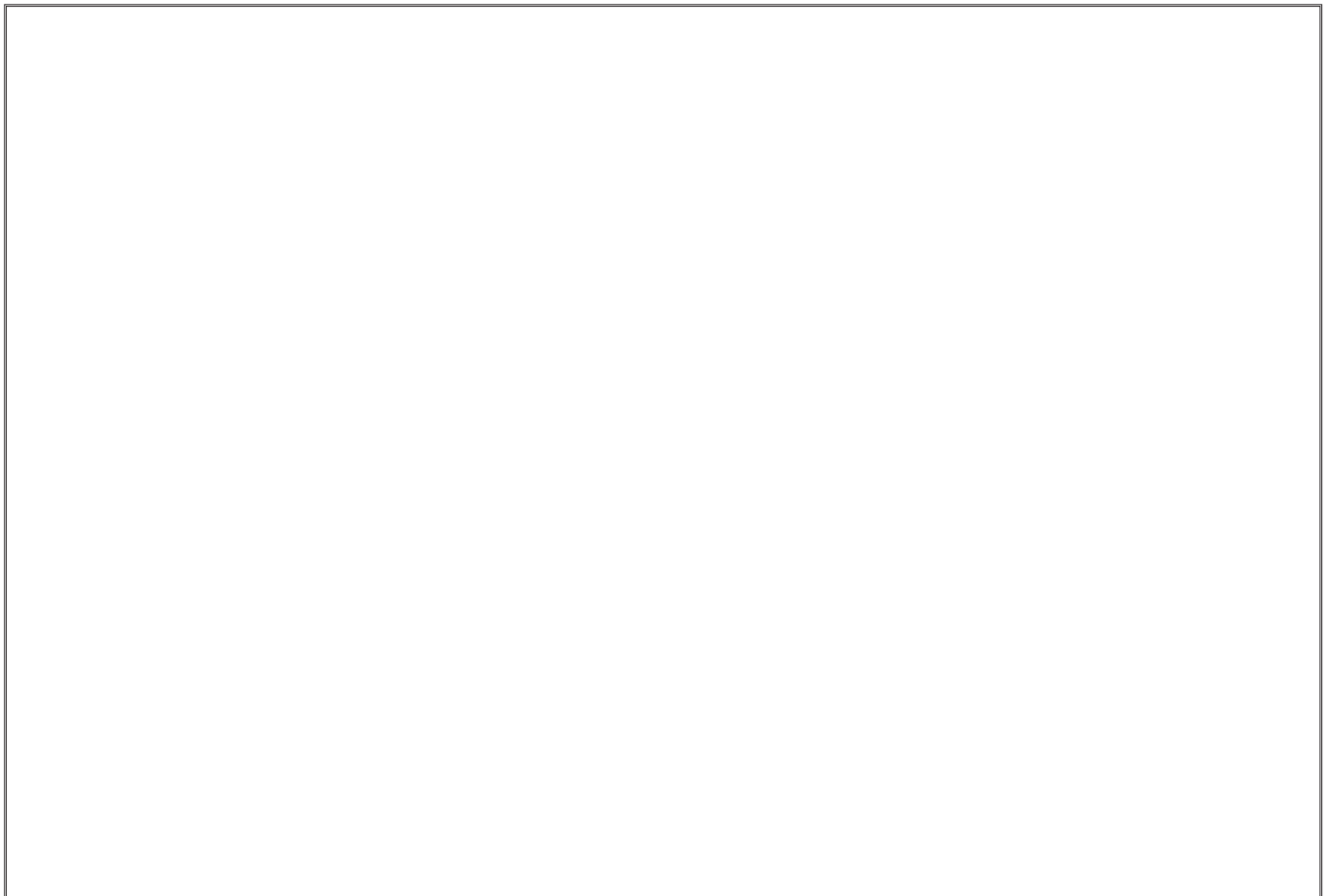

Activity 15: Make your family puppets.

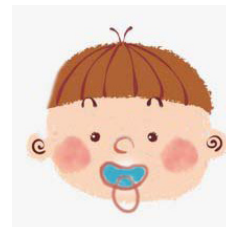
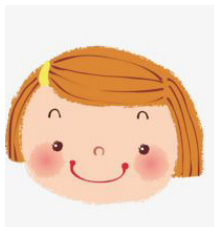
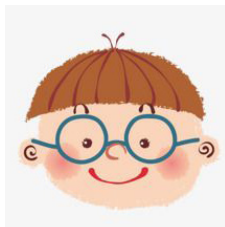
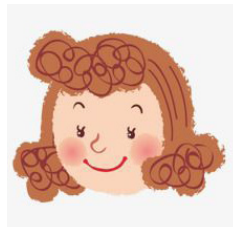

Activity 16: Make your own puppets.



Activity 17: Make your favorite animal Puppets.



1

Unit

Self-Introductions

Activity 1: Trace and color.



Hello Hi

Goodbye bye



Activity 2: Complete with vowels.



H__ll__



By__

6

Unit

My Family

Activity 1: Color and match.

Brother

Dad

Grandpa

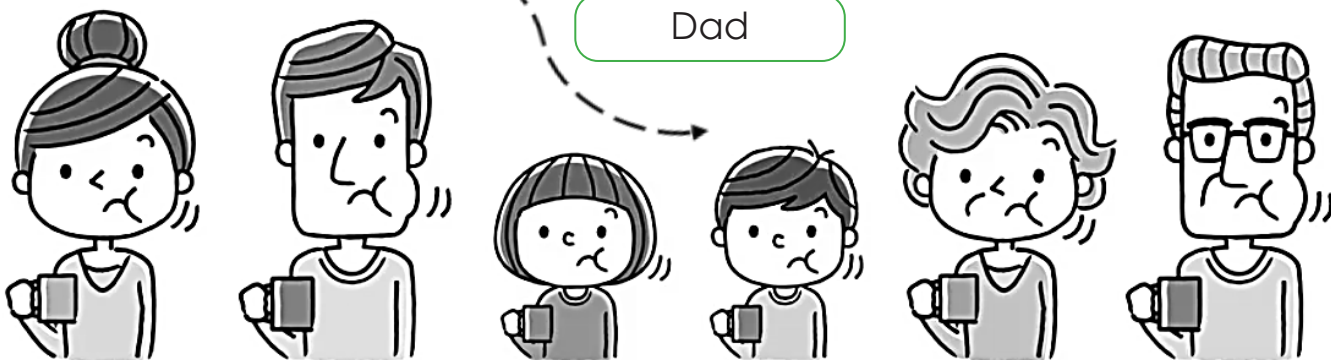

Grandma

Mom

Sister

Activity 2: Trace the sentences.



This is my dad.



This is my mom.



This is my sister.



This is my brother.



This is my grandma.



This is my grandpa.

Activity 3: Listen and check (✓).

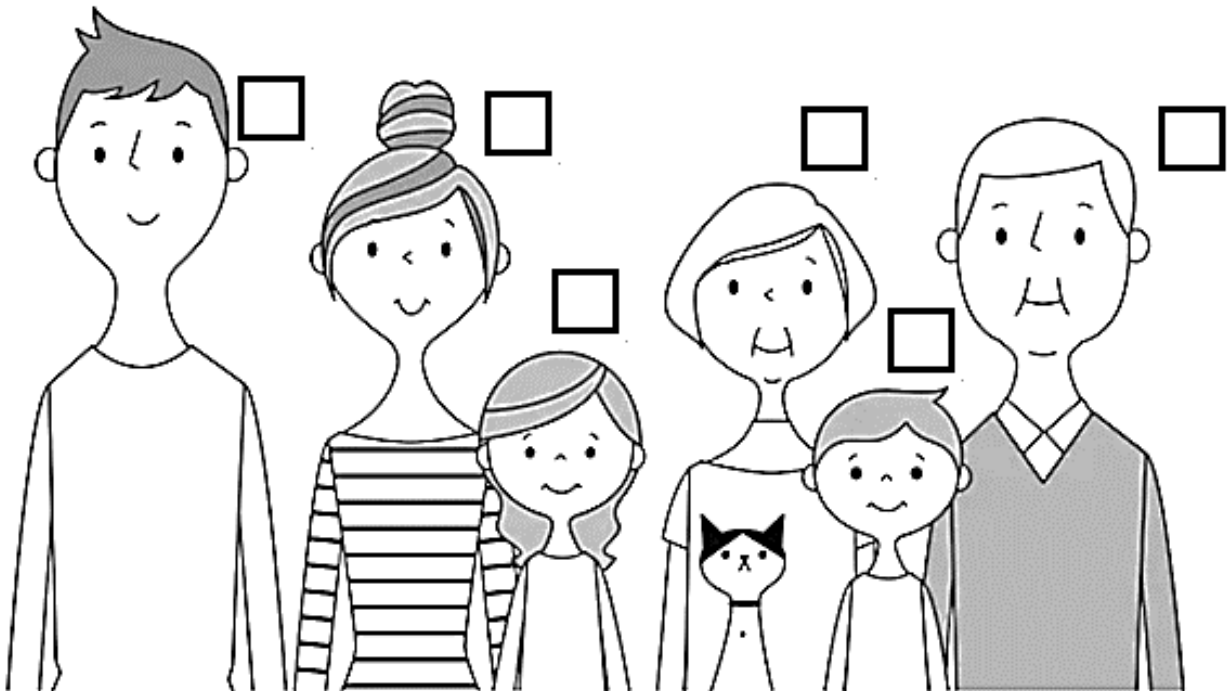

Activity 5: Complete and draw about family.

This is my _____.

This is my _____.

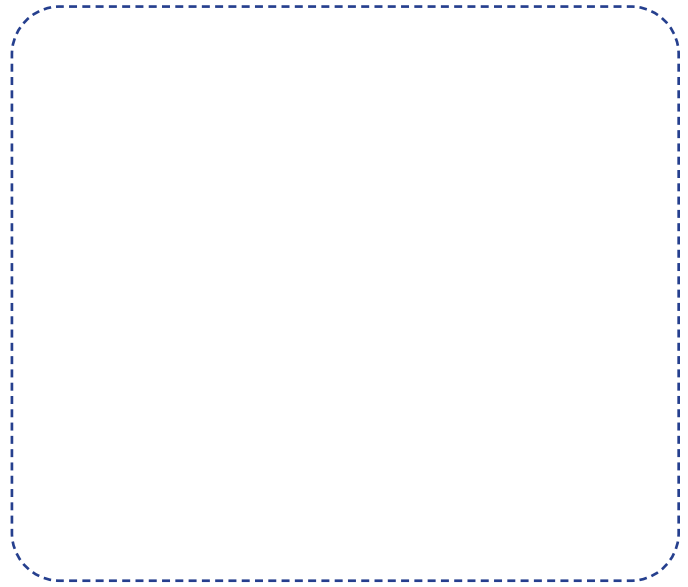
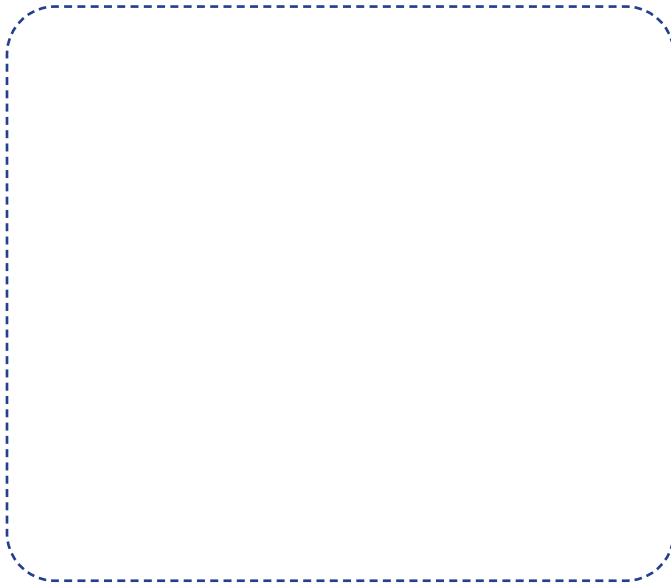

Activity 6: Color and complete with vowels.

1. Gr__ndm__
2. M__
3. S__st__r
4. Gr__ndp__
5. D__d
6. Br__th__r

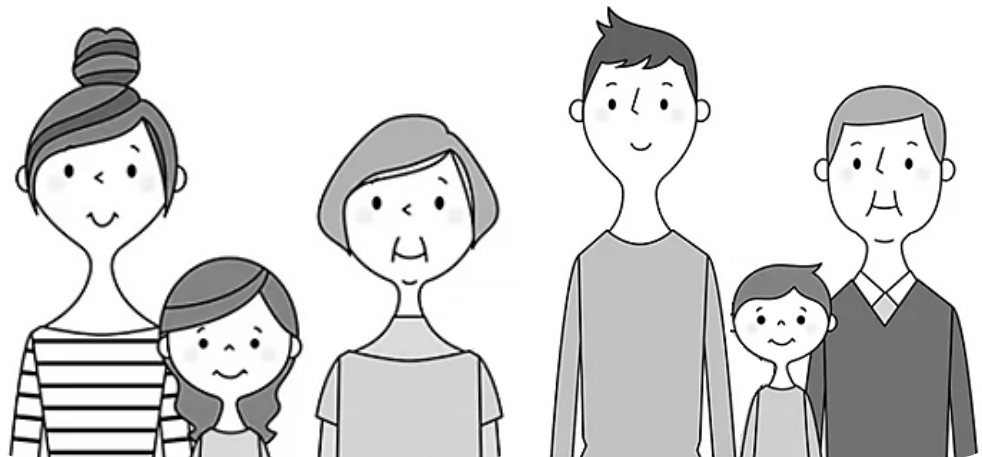

Activity 6: Listen and color.



One



Two



Three

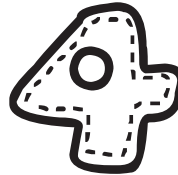

Four



Five



Six



Seven

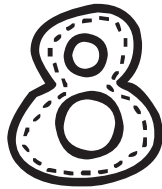

Eight



Nine

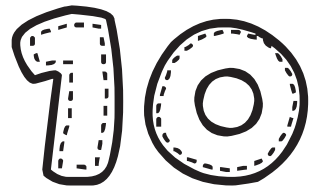

Ten

Activity 7: Trace and color.

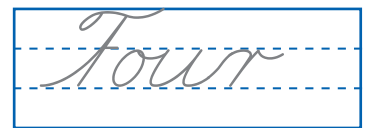
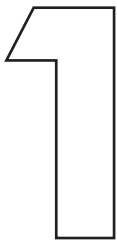

5

Five

8

Eight

6

Six

9

Nine

7

Seven

10

Ten

Activity 8: Count and match.

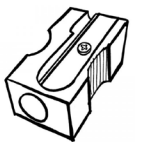
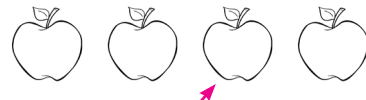
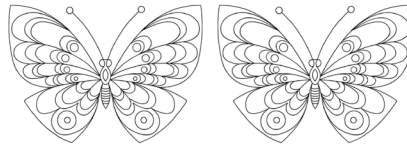
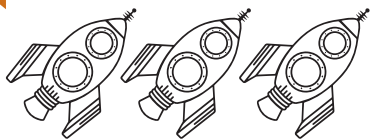

1 5 6 8 9



7 3 10 2 4

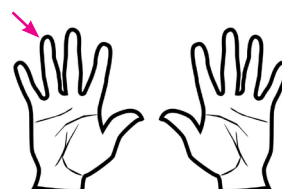
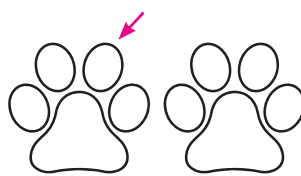

Activity 9: Color and Trace.

How old are you?

I'm 6

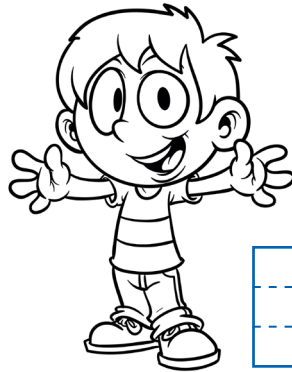

I am Six

Activity 10: Draw, color and answer the question.

How old are you?

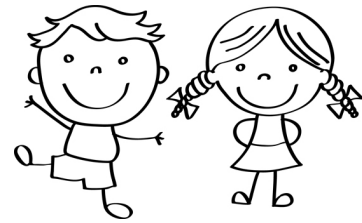

I am

Activity 11: Listen and Check (✓).

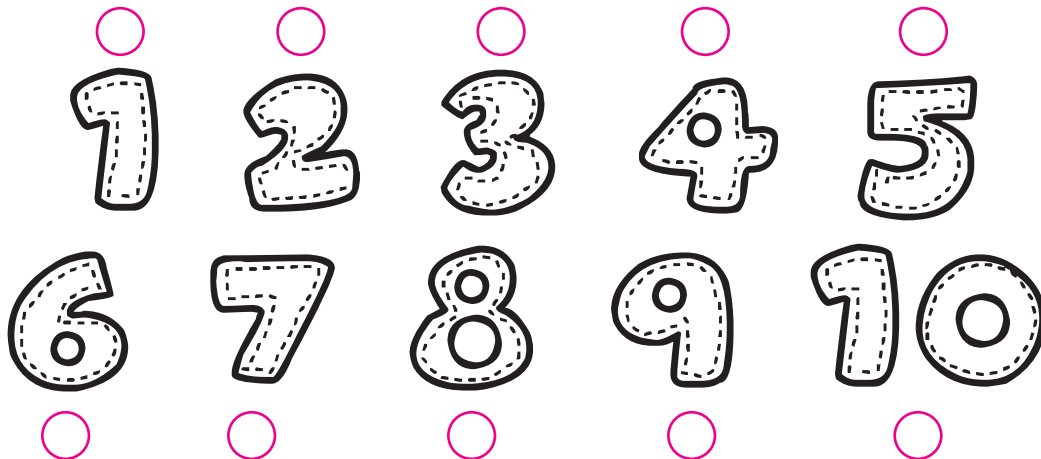

Activity 3: Listen and color.

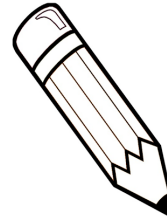
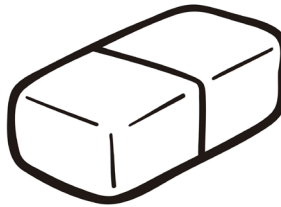
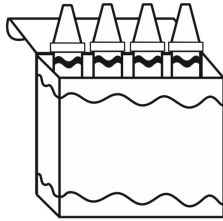
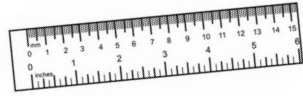
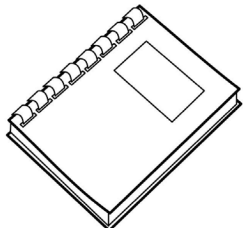

Activity 2: Look and match.

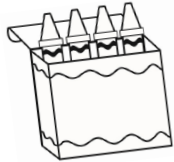

Crayons

Glue

Pencil

Ruler

Notebook

Eraser

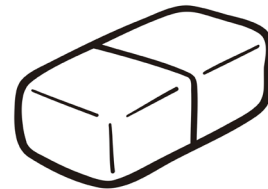
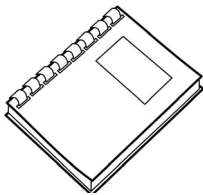

Activity 4: Trace and color.

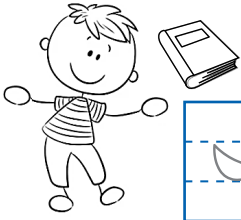

I have a sharpener.

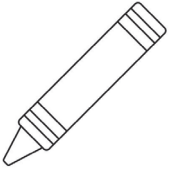

I have a crayon.

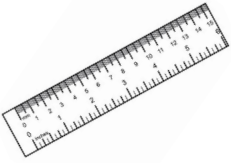

I have a ruler.

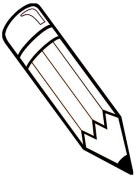

I have a pencil.



I have a pen.



I have an eraser.

Activity 1: Listen, color and trace.



Dog



Cat

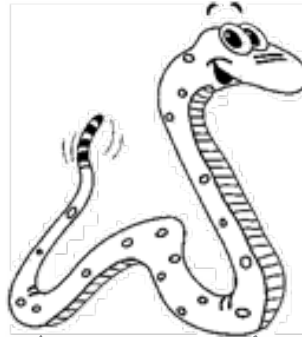

Snake

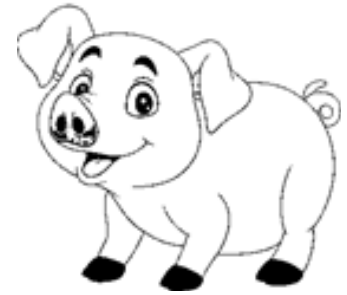

Pig



Rabbit



Opossum



Fox



Cow



Horse



Donkey



Owl



Bird



Squirrel

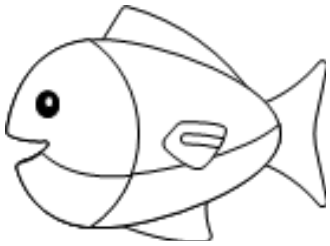

Fish



Bug



Butterfly

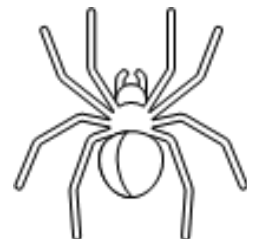

Spider

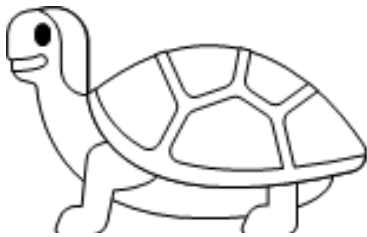

Turtle

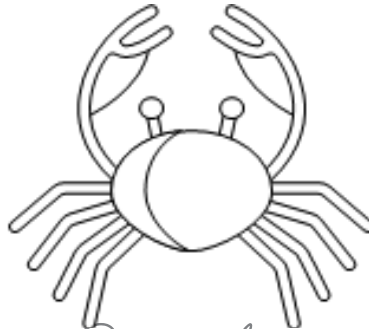

Crab



Snail



Deer



Eagle

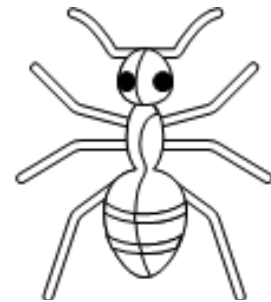

Ant

Activity 3: Color the hands and trace the word.

○ Left hand - Goodbye: red ○ Right hand- Hello: green

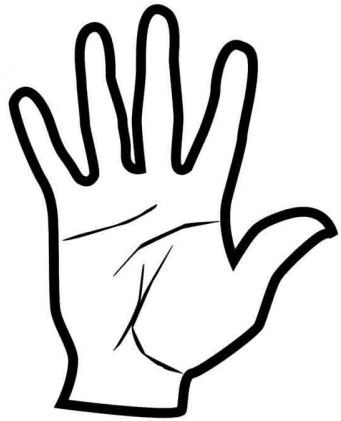

Goodbye

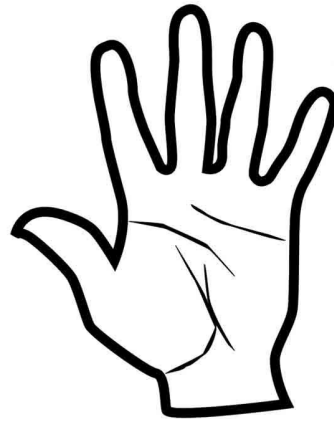

Hello

Activity 4: Match and color.



○ *Hello*



○ *Goodbye*

Activity 5: Trace and complete.

What's your name?

What's your name?

What's your name?



My name's

My name's

My name's

My name's



Activity 2: Look and match.

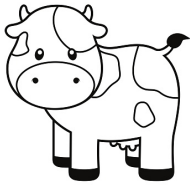

Dog

Pig

Rabbit

Bird

Owl

Cat

Snake

Horse

Cow

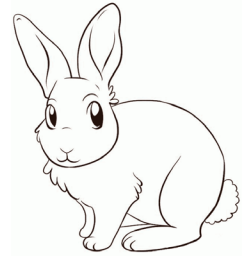
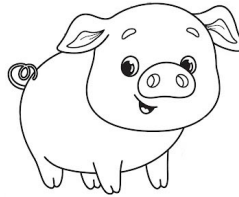
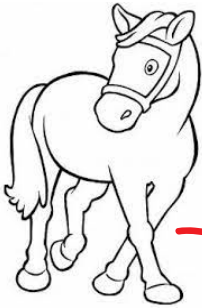
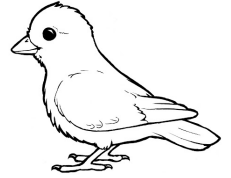

Activity 3: Complete with vowels.

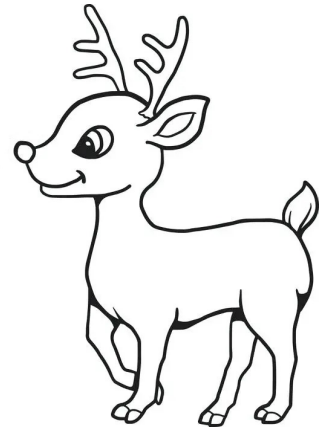
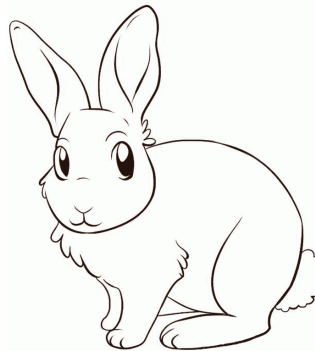
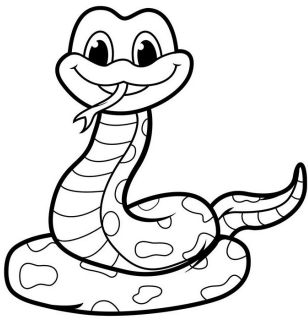

Sn_k_

_wl

R_bb_t

D__r

Activity 4: Trace the sentences.

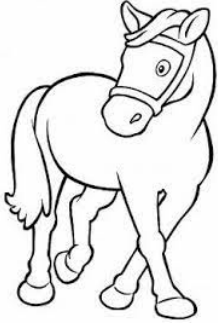

It's a horse.

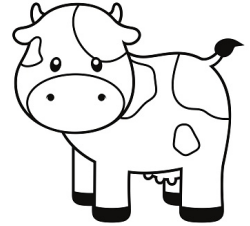

It's a cow.



It's an eagle.



It's an owl.

Activity 5: Complete with "a" or "an".



It's ___ cat

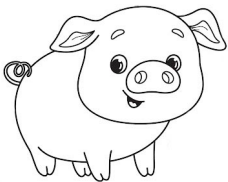

It's ___ pig

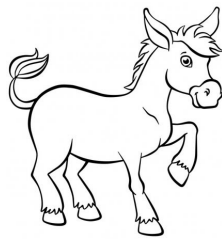

It's ___ horse



It's ___ owl



It's ___ deer

Activity 6: Circle it's or it isn't.

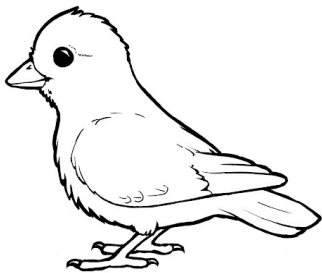

It's / it isn't a bird.

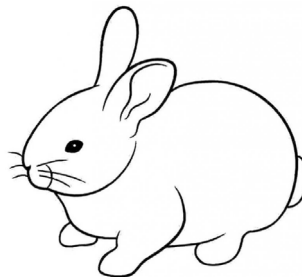

It's / it isn't a donkey.

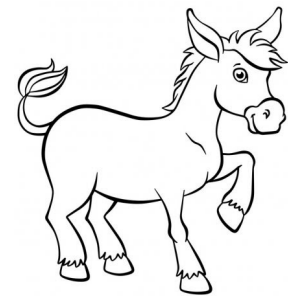

It's / it isn't a rabbit.

Activity 1: Listen, color and trace.

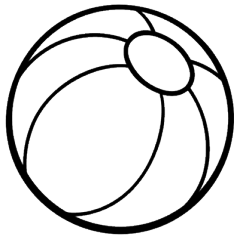

Ball

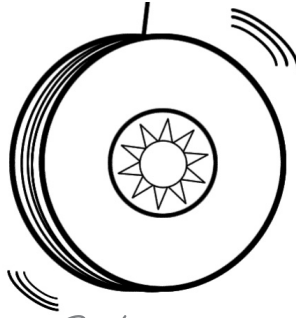

Yo yo



Doll

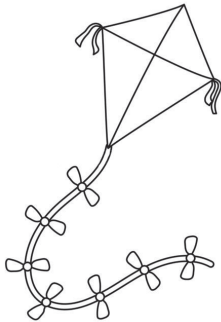

Kite

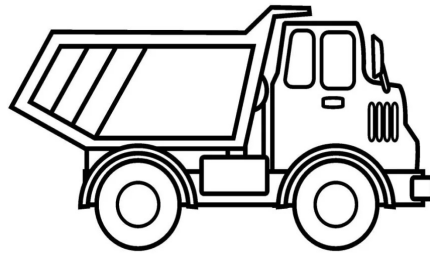

Truck



Teddy
bear



Helicopter

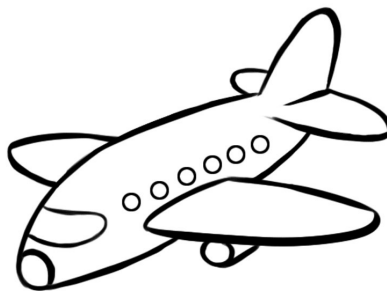

Plane

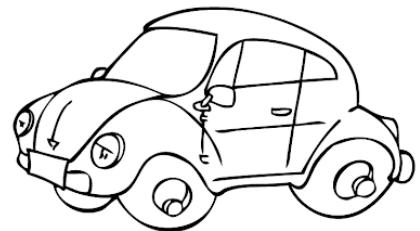

Car

Activity 2: Count and complete.

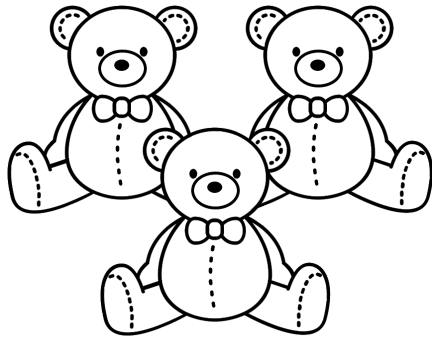

_____ Teddy bears



_____ Planes

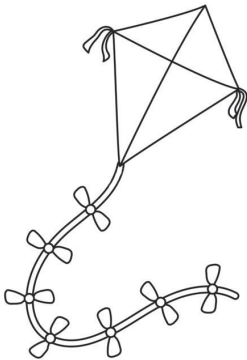
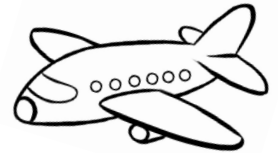

_____ Kite

Activity 3: Listen and number.

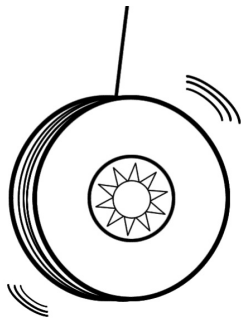

○

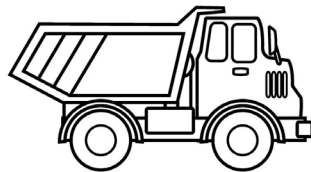

○



○

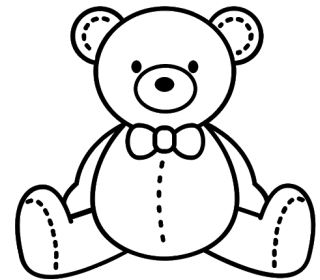

○

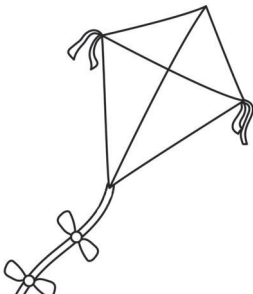

○



○



○



○

Activity 4: Look and complete.

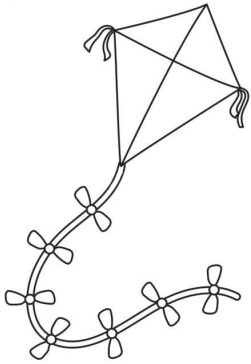

It's a kite.

It's a



It's a

It's a

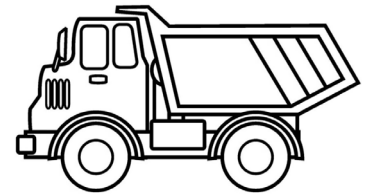

Activity 5: Circle Yes, it is or No, it isn't

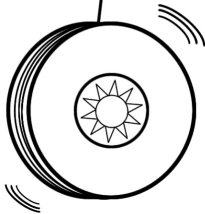

Is it a truck? Yes, it is
 No, it isn't



Is it a ball? Yes, it is
 No, it isn't



Is it a kite? Yes, it is
 No, it isn't

Activity 6: Look and draw.

Yoyo



Teddy bear



Activity 7: Color.

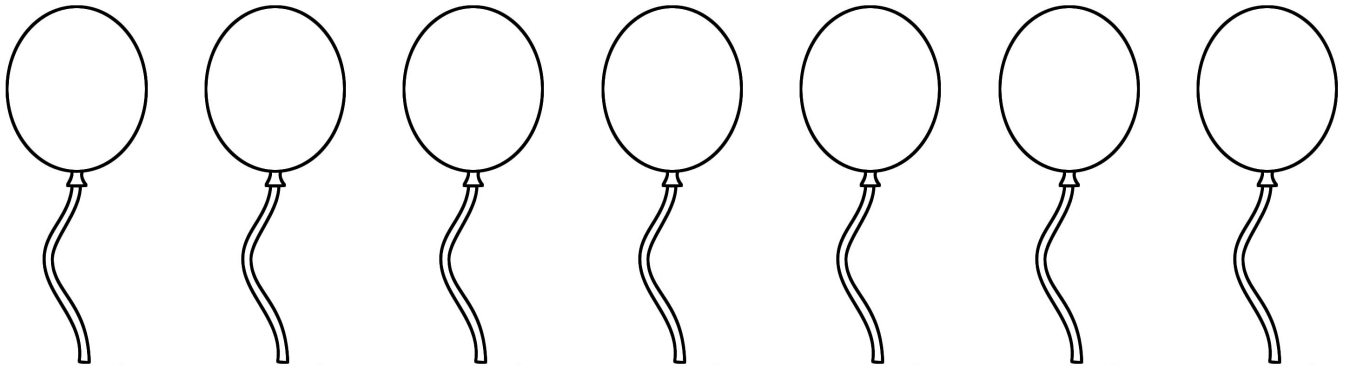

Red

Green

Yellow

Blue

Orange

Pink

Purple

Activity 8: Look and match.

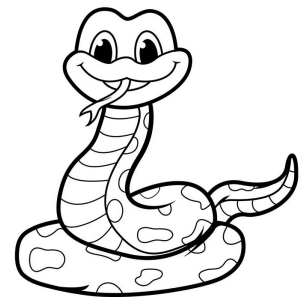
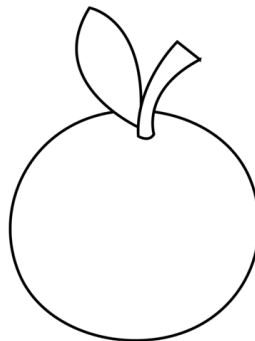
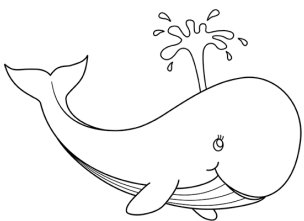

Orange

Blue

Green

Yellow

Activity 9: Complete with a color word.

What color is it?

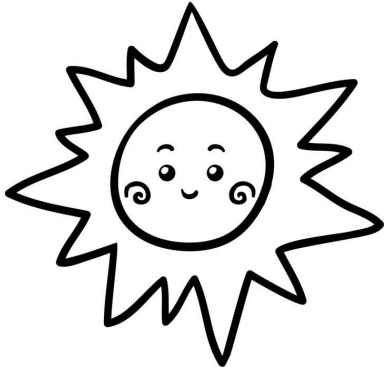

It's _____

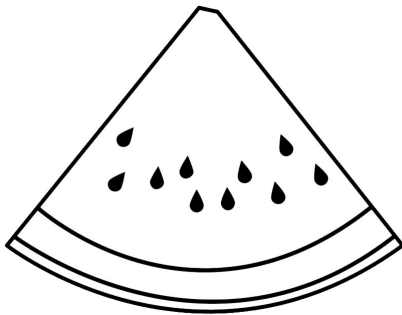

It's _____ and _____

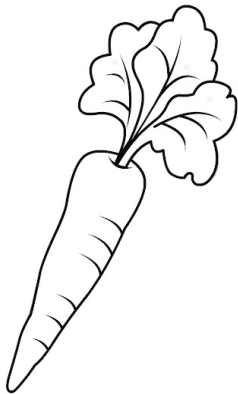

It's _____

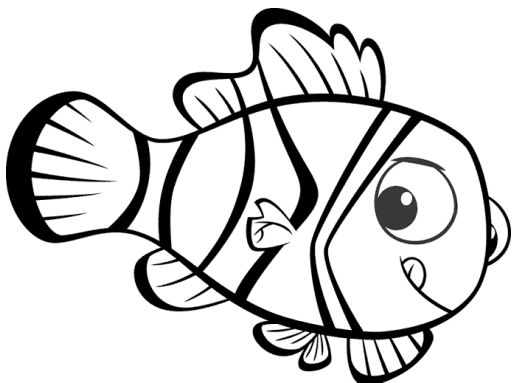

It's _____

5

Unit

Where is it?

Activity 1: Listen and trace the words.

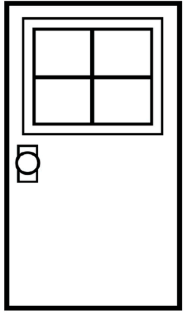

Door

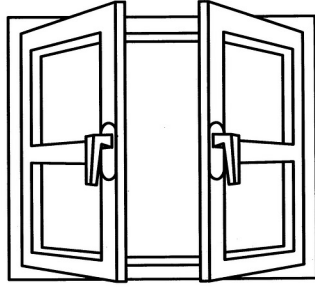

Window

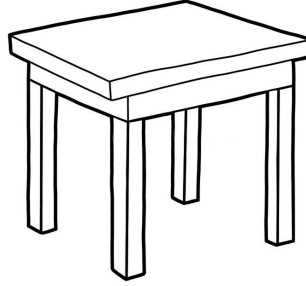

Table

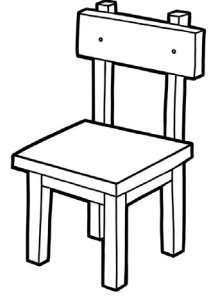

Chair



Map



*Water
bottle*

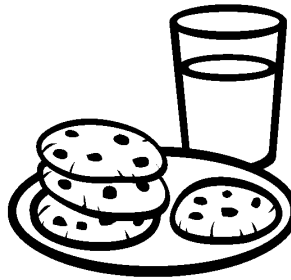

Snack

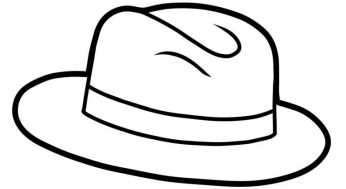

Hat

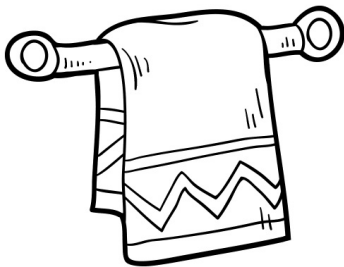

Towel



Backpack

Activity 2: Listen and number.

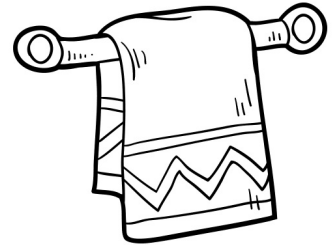
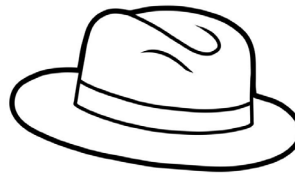
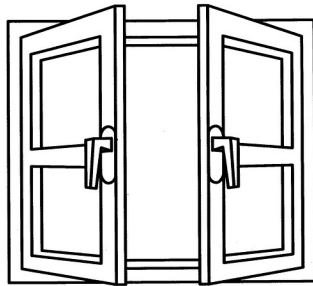
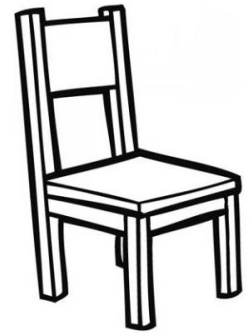
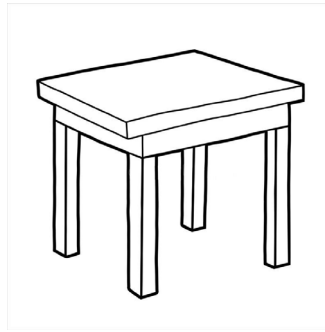
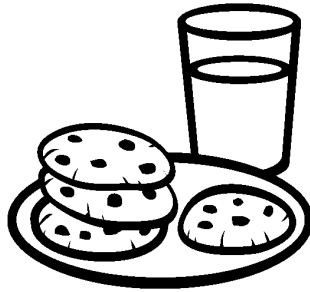
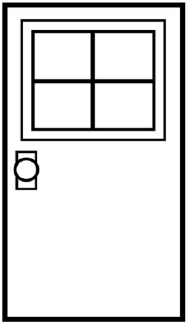

Activity 3: Complete with vowels.



M_p

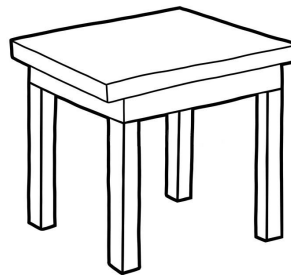

T_b_e



W_ter
B_ttl_

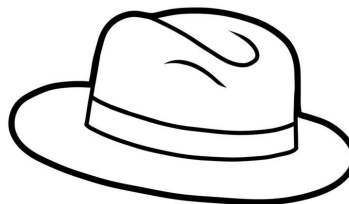

H_t

Activity 4: Look and match.

Table

Window

Backpack

Snack

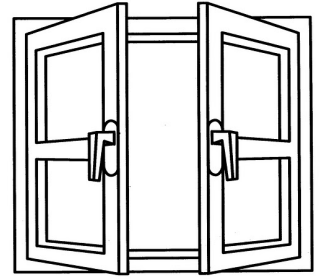
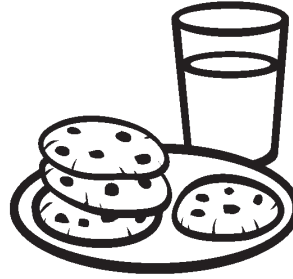
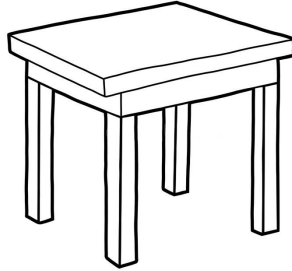

Activity 5: Circle "In" "on" or "under".

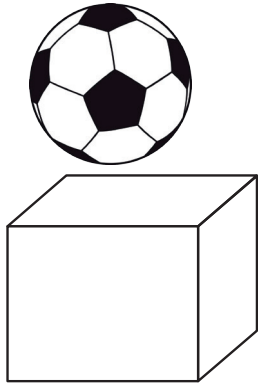

It's in / on / under the box

It's in / on / under the box

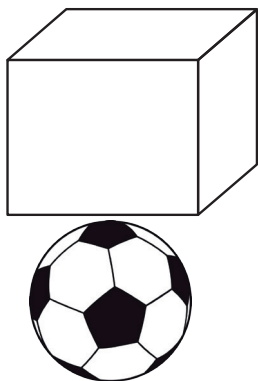
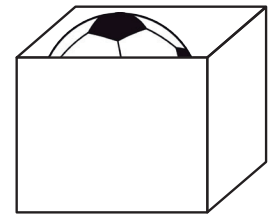

It's in / on / under the box

Activity 6: Look and answer.

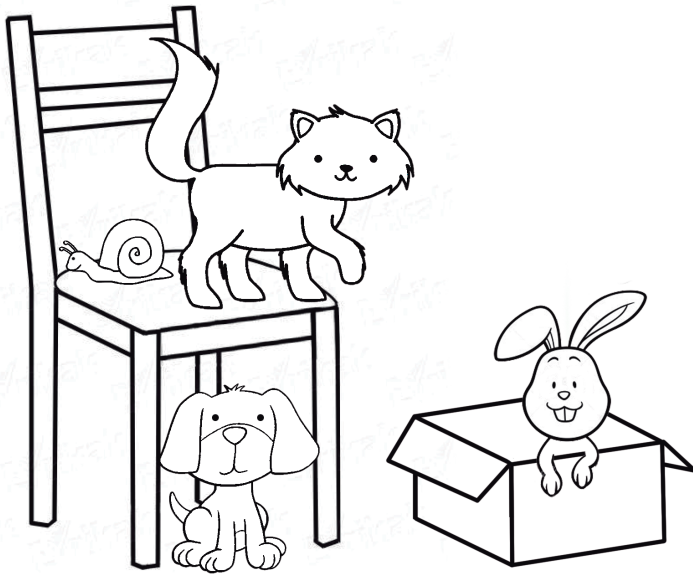

Where's the snail?

It's on the chair.

Where's the cat?

_____.

Where's the dog?

_____.

Where's the rabbit?

_____.

Activity 7: Draw and color.

The pen is on the table.

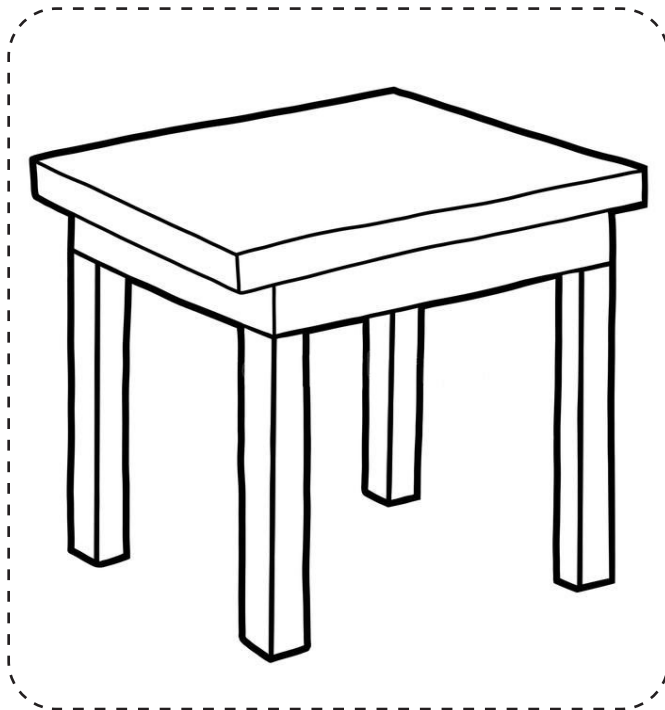

The ball is under the chair.

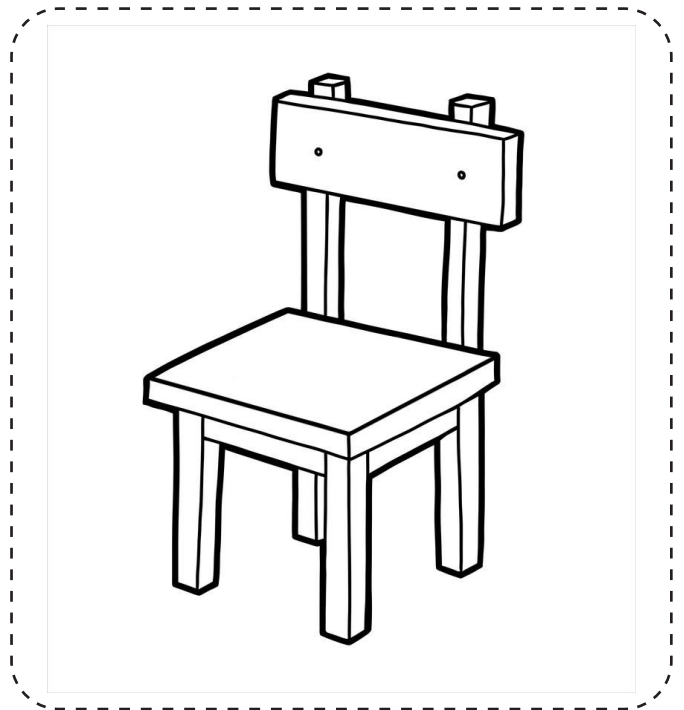

Activity 1: Color and trace.

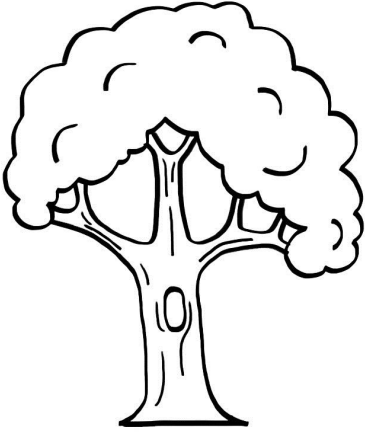

Tree



Plant

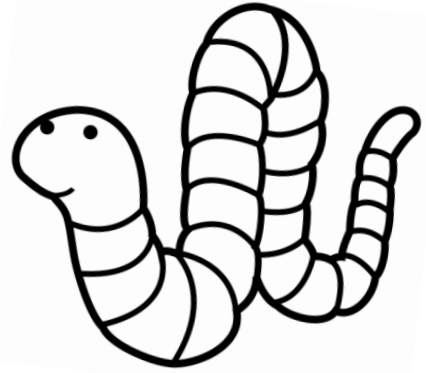

Caterpillar

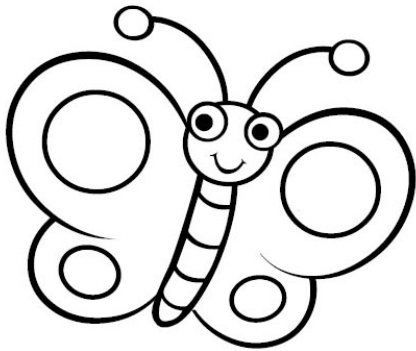

Butterfly

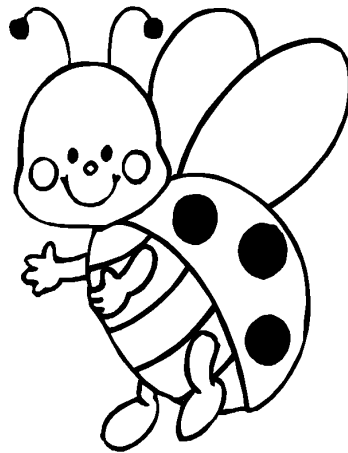

Ladybug



Frog

Activity 2: Check (✓) Yes or No.



Tree
 Yes No

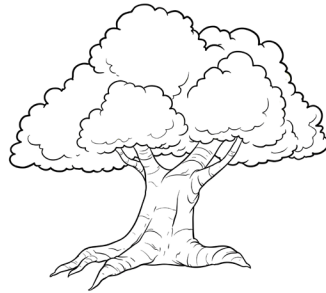

Tree
 Yes No



Frog
 Yes No

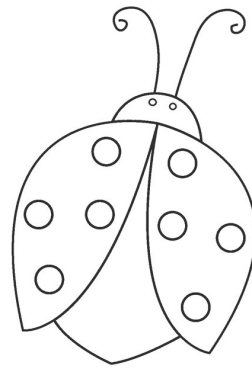

Plant
 Yes No

Activity 3: Trace the sentences.

What are they?

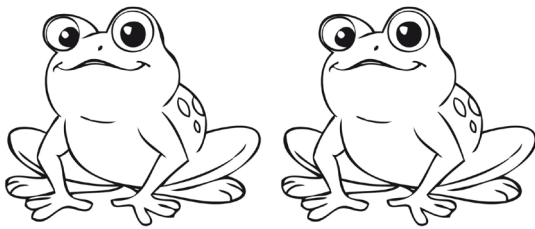

They're frogs.

Activity 4: Read and trace the sentences.

A red



is on a green



A red ladybug is on a green plant.

A brown



is under a green



A brown frog is under a green tree.

Activity 5: Spell the words.

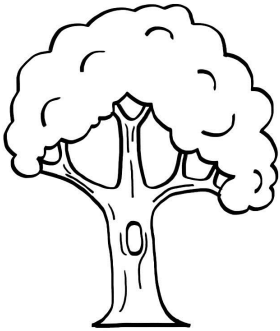

S T P

tree



R L F

frog



P F M

plant

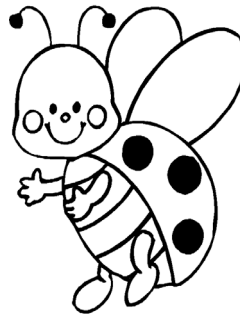

P L R

ladybug

Activity 6: Circle six color words.

b	e	i	g	e	p
r	g	p	r	b	u
o	l	i	a	r	r
w	p	n	y	i	p
n	e	k	l	w	l
o	r	a	n	g	e

- Gray
- Purple
- Orange
- Beige
- Brown
- Pink

Activity 7: Circle.

Are they snakes?

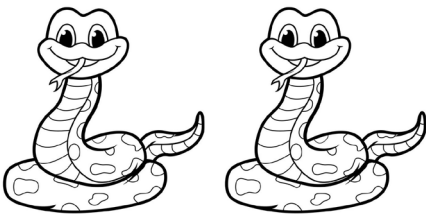

- a. Yes, they are.
- b. No, they aren't

Are they frogs?

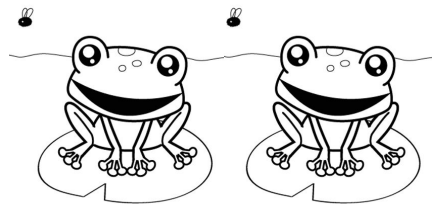

- a. Yes, they are.
- b. No, they aren't

Are they trees?

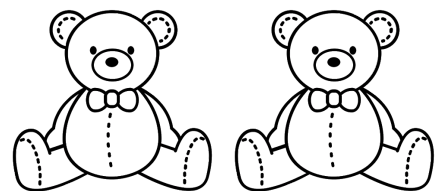

- a. Yes, they are.
- b. No, they aren't

Are they ladybugs?

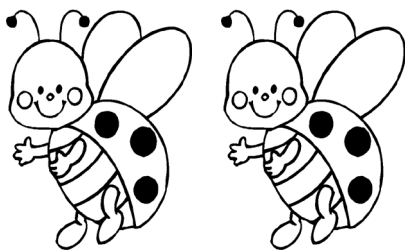

- a. Yes, they are.
- b. No, they aren't

Are they frogs?

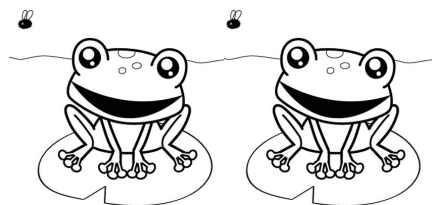

- a. Yes, they are.
- b. No, they aren't

Are they plants?

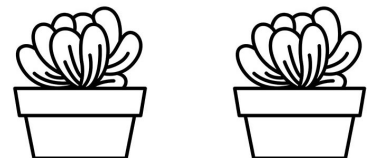

- a. Yes, they are.
- b. No, they aren't

7

Unit

My House?

Activity 1: Color and say.

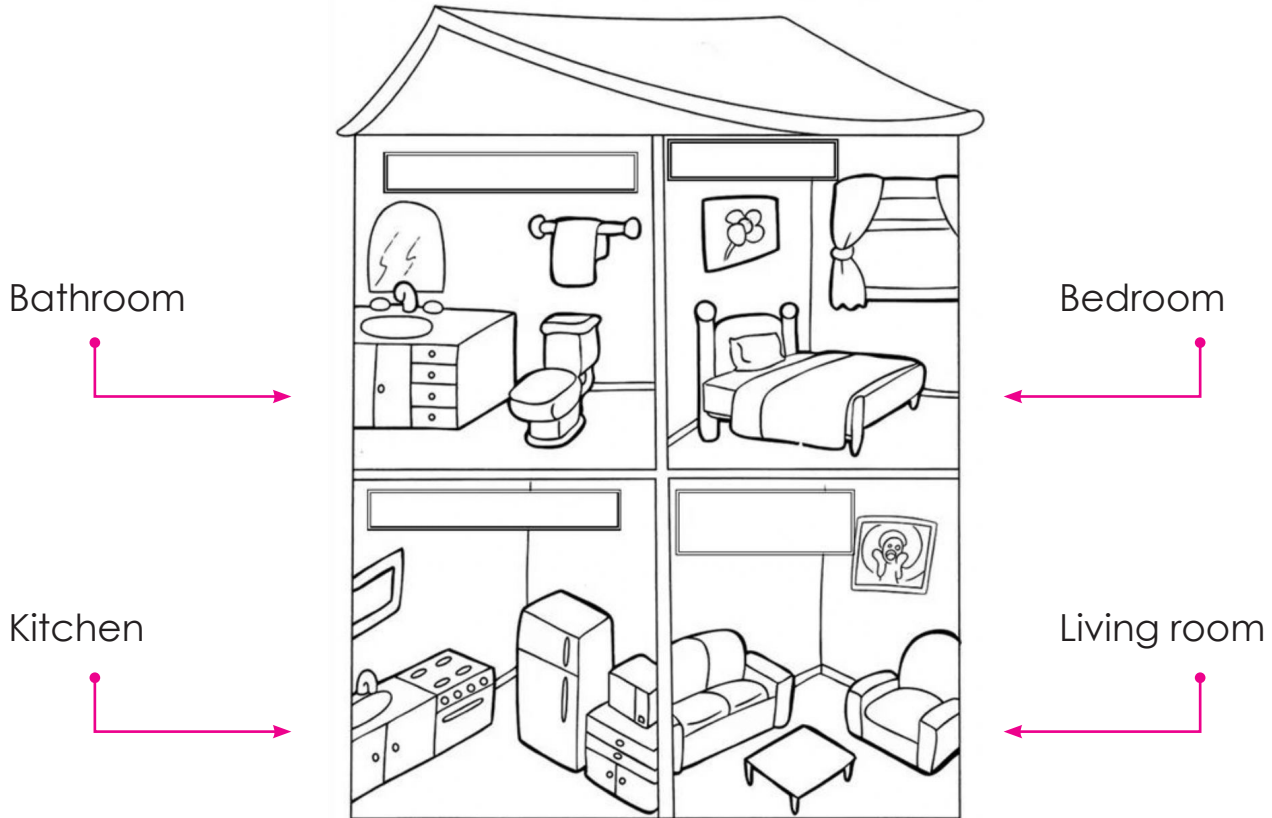

Activity 2: Circle the word.

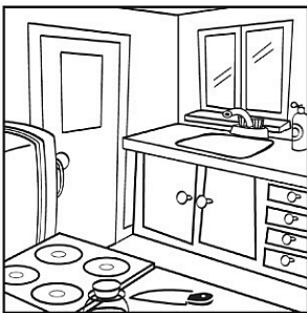

- a. Living room
- b. Bedroom
- c. Bathroom
- d. Kitchen

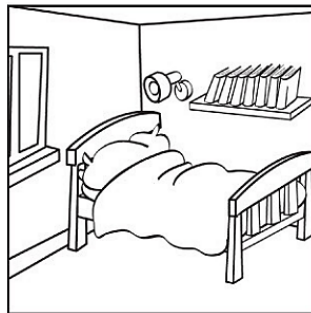

- a. Living room
- b. Bedroom
- c. Bathroom
- d. Kitchen



- a. Living room
- b. Bedroom
- c. Bathroom
- d. Kitchen

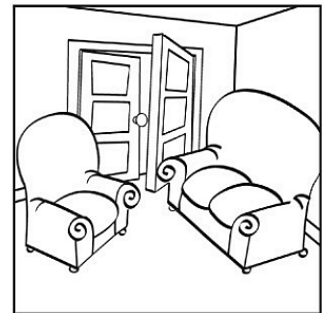

- a. Living room
- b. Bedroom
- c. Bathroom
- d. Kitchen

Activity 3: Trace the sentence.

I like my house.

Activity 4: Trace and match.

Bedroom

Kitchen

Living room

Bathroom

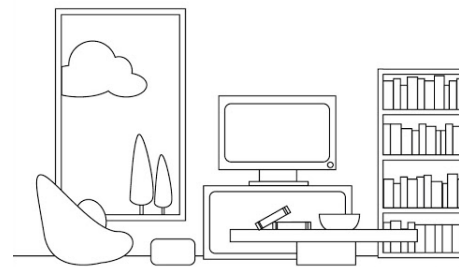
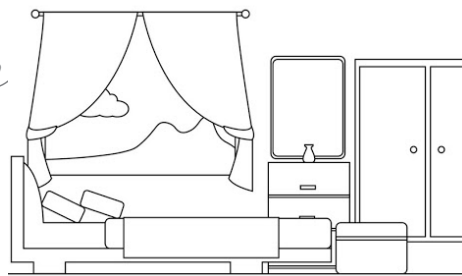
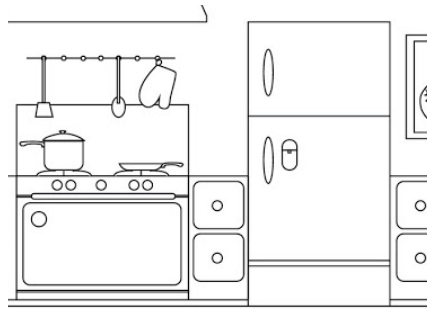

Grammar Check!

Singular: There **is**
There is a kitchen.

Plural: There **are**
There are two bedrooms.

Activity 5: Complete with is or are.

There _____ a kitchen in the house.

There _____ two bathrooms in the house.

There _____ a living room in the house.

There _____ four bedrooms in the house.

Activity 6: Count and write.

How many ... are there?

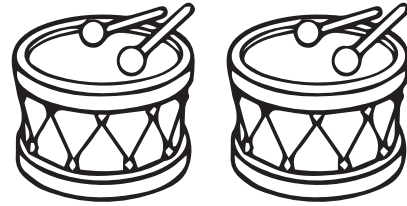

There are four apples.

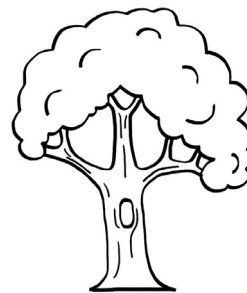
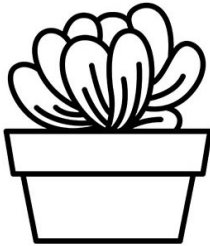

Activity 5: Trace the numbers.

11

Eleven

12

Twelve

13

Thirteen

14

Fourteen

15

Fifteen

16

Sixteen

17

Seventeen

18

Eighteen

19

Nineteen

20

Twenty

Activity 1: Trace the words.

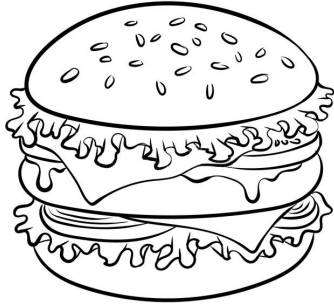

Hamburger

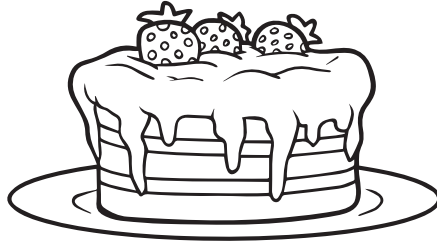

Cake

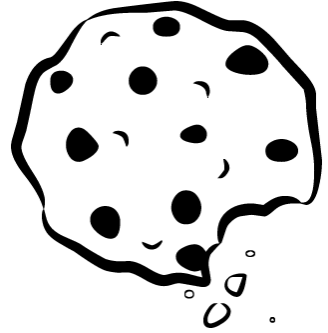

Cookie

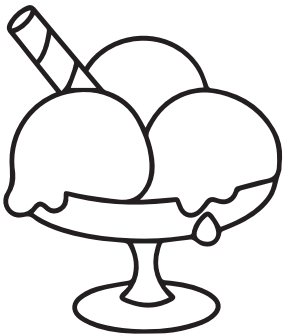

Ice Cream

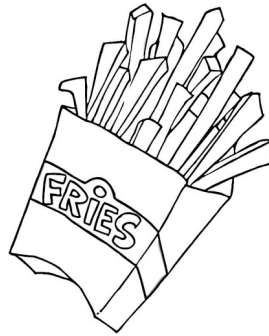

French
fries

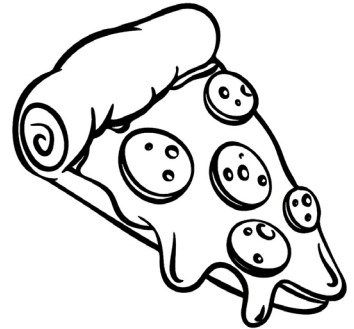

Pizza

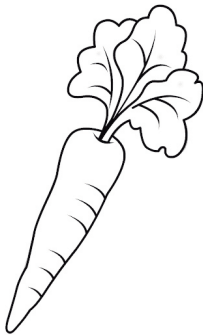

Carrot



Banana

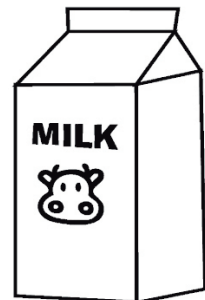

Milk

Grammar Check!



I like



I don't like



Activity 2: Draw some food you like/don't like.



Two large dashed-line boxes for drawing. The left box is under the thumbs up icon, and the right box is under the thumbs down icon.

Activity 3: Write sentences with I like/ I don't like.



I like ice cream.



Blank writing lines for the sentence: I like _____.

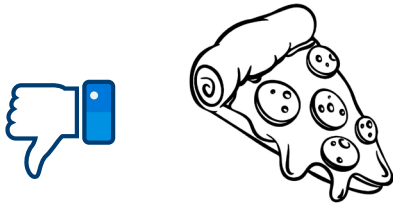

Blank writing lines for the first row.

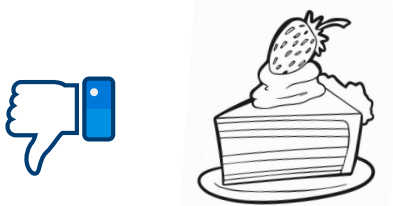

Blank writing lines for the second row.

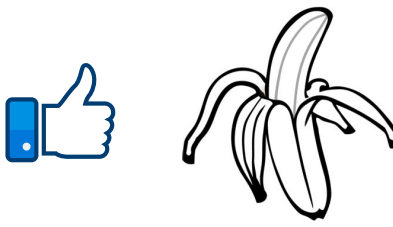

Blank writing lines for the third row.

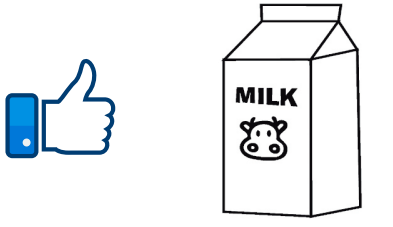

Blank writing lines for the fourth row.

Activity 4:

Read and mark (✓) correct or (X) incorrect.



It's a pizza



It's a banana



It's a hamburger



It's a carrot



It's a pizza



It's a cookie

Webgraphy

Llanas, Angela & Williams Libby, (2015). Happy Campers Student Book Edition 1. Macmillan Education.

Imagines, adobe stock. Copyc2021 adobe. All right reserved

www.pinteres.com

www.Freepikvectores.com

www.vectorstock.com

www.Shutterstock.com

www.pixaby.com/ilustration

<https://www.cambridge.es/catalogo/infantil/cursos/little-steps/componentes#activity-book>

<https://www.cambridge.es/catalogo/infantil>